

THE ROUGE RIVER PROJECT
A WORLD CLASS EFFORT

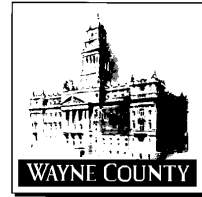

BRINGING OUR RIVER BACK TO LIFE



ONSITE SEWAGE DISPOSAL SYSTEM DATA MODEL

**PRELIMINARY DRAFT
APRIL 1999**

SPONSORED BY

**WAYNE COUNTY ROUGE PROGRAM OFFICE
AND THE
ROUGE WATERSHED COMMUNITIES**

This document has been developed to provide the Rouge River watershed communities a data base design template to use in building their onsite sewage disposal system (OSDS) coverage and related attribute tables. The database tables provided herein have been developed through several workshop meetings and incorporate the comments of several Rouge communities at various stages of GIS development.

There are three types of Rouge communities who will benefit from this document:

1. Communities that are building just an attribute data base for their OSDS. This type of community may or may not have GIS tools available to supplement their work.
2. Communities that are building their GIS using ArcView and planning to store the attributes in some desktop data base environment.
3. Communities that are building their GIS using Arc/Info and store their attributes in INFO tables or a relational data base management system like Oracle, Informix or Ingres, linked to Arc/Info.

The information provided in this document is focused on the OSDS attribute tables and any Arc/Info or ArcView tables required to link the attributes to the spatial data in the GIS. There is a unique feature identifier created in each feature attribute table (Section 1) and also listed in the Arc/Info tables (Section 3) and ArcView tables (Section 4). This feature identifier (FAC_ID) is the link between the feature attribute tables defined in this document and the GIS spatial features that may be created by a community GIS program.

If the community is building spatial features as they build their attribute data base, there is one very important function that must be conducted that is NOT described in this document. Assuming that each feature attribute table presented in this document is going to eventually be a graphic feature in the community GIS, then a structured approach to the naming convention used for the feature identifier (FAC_ID) must be pre-defined and used during both graphics development and attribute development. This is very, very important especially for those communities building just the attribute tables at this time to meet the requirements of the general permit OR those communities building just the spatial graphic features at this time. The two can not be linked unless the feature identifier (FAC_ID) in the GIS is the same as the FAC_ID in the attribute tables.

Other GIS development issues not covered in this document relate among others, to feature map projection, coordinate system, feature symbology, and conversion methods that a community must define before embarking on the graphics development phase of their program.

The sections of this document include:

- Section 1. ODS Feature attribute tables definitions
- Section 2. Support table or Look up / Code table for the Attribute data tables
- Section 3. Arc/Info table definitions. For use by those communities using Arc/Info to build their OSDS coverage
- Section 4. ArcView table definitions for use by communities using ArcView to build their OSDS themes.

Throughout this document a specific nomenclature has been used. These are:

OSDS_XXXXX	OSDS attribute table name
YYY_CODE	OSDS support / look up table name
AAA_BBB_CCC	OSDS field names
Numeric	Field type equals a number (Decimal or Integer) field
Text	Field Type equals an alpha-numeric or character field
Key	Field type equals a look up key in a supporting code table
Date	Field type equals date (MM/DD/YYYY)
Memo	Field Type equals a memo text box.
FAC_ID	Each feature has a unique user defined identifier using a common field name.

Comments and inputs have been provided by several Rouge watershed communities. Wayne County and Oakland County Health Departments have also been very active in designing these data tables.

**SECTION 1.
ONSITE SEWAGE DISPOSAL SYSTEM
FEATURE TABLES**

There are four OSDS feature tables defined in this database. These tables consist of all three types of features - lines (arcs); points) nodes); and areas (polygons). A definition table is defined for each OSDS feature which include:

OSDS_LOC
OSDS_BLDG
OSDS_SEPTIC
OSDS_MAINT

These tables, which the community can use to develop their OSDS database, include the following information:

Field Name - Data base field name (does not follow 8.3 format)
Data Type - Type of data (Text / character, numeric, key, memo)
Data Size - the size of the data field, Numeric decimal is implied in format.
Description - a brief description of the field

The primary key field of each table is identified using a **BOLD font**.

TABLE NAME: OSDS_LOC

This table describes the location of the parcel that contains the onsite sewage disposal system. This table MAY be populated via a link to a communities parcel information management system. The link to the parcel assessment files would be the parcel ID or SIDWELL number. There could be many ODSD_BLDG on one OSDS_LOC.

FIELD NAME	DATA TYPE	SIZE	DESCRIPTION
PARCEL_ID	TEXT	20	UNIQUE FEATURE ID – PRIMARY KEY / USER DEFINED – PARCEL ID OR SIDWELL NUMBER
COMMENTS	MEMO		MEMO TEXT TO DOCUMENT MISC. INFORMATION
RESD_LNAME	TEXT	20	RESIDENT LAST NAME
ST_NUM	NUMERIC	15	STREET NUMBER OF THE HOUSE / BLDG
ST_PREFIX	TEXT	10	STREET PREFIX (NORTH, SOUTH, WEST, EAST)
ST_NAME	TEXT	25	STREET NAME
ST_SUFFIX	TEXT	10	STREET SUFFIX (ST., BLVD, AVE., LN, ETC.)
ZIP_CODE	NUMERIC	99999	ZIP CODE
PHONE	NUMERIC	999.999.9999	PHONE NUMBER
CVT_CODE	KEY		CVT_CODE TABLE

REVIEW COMMENTS

TABLE NAME: OSDS_BLDG

This table describes the actual building or home on the parcel that the septic system (OSDS) is attached. There may be many OSDS_SEPTIC for one OSDS_BLDG depending on the size or the years of service.

FIELD NAME	DATA TYPE	SIZE	DESCRIPTION
BLDG_ID	TEXT	15	UNIQUE FEATURE ID – PRIMARY KEY / USER DEFINED
COMMENTS	MEMO		MEMO TO DOCUMENT MISC. INFORMATION
NO_BEDROOM	NUMERIC	99	NUMBER OF BEDROOMS IN THE HOME / BUILDING
NO_PEOPLE	NUMERIC	99	NUMBER OF PEOPLE IN THE HOME / BUILDING
NO_BATHROOM	NUMERIC	99	NUMBER OF BATHROOMS IN THE HOME / BUILDING
YR_BUILT	NUMERIC	9999	YEAR ORIGINAL HOUSE / BUILDING WAS BUILT
SEWER_AVAIL	LOGICAL	YES / NO	IS A SEWER SYSTEM AVAILABLE WITHIN 200 FEET TO THE HOUSE / BUILDING?
PERC_RATE	NUMERIC	999.99	PERCOLATION RATE FROM TEST (INCHES / HR)
PARCEL_ID	TEXT	15	UNIQUE LOCATION AND ADDRESS OF BUILDING. LINK TO ODSO_LOC TABLE
WELL	LOGICAL	YES / NO	IS THERE A DRINKING WATER WELL FOR THIS HOUSE / BUILDING ?
BLDG_TYPE_CODE	KEY		SEE BLDG_TYPE TABLE

REVIEW COMMENTS

TABLE NAME: OSDS_SEPTIC

This table would contain the information about the actual septic tank and drain field system. There would be only one septic tank system for each permit. In some cases, there may be more than one septic tank permit for a single house / building.

FIELD NAME	DATA TYPE	SIZE	DESCRIPTION
PERMIT_ID	TEXT	15	UNIQUE FEATURE ID – PRIMARY KEY / USER DEFINED – PERMIT NUMBER ASSIGNED
COMMENTS	MEMO		MEMO TEXT TO DOCUMENT ANY MISC. INFORMATION
NO_TANKS	NUMERIC	99	NUMBER OF SEPTIC TANKS ATTACHED TO HOUSE / BUILDING (DEFAULT = 1)
X_LOC	NUMERIC	9999.99	X LOCATION OF SEPTIC TANK
Y_LOC	NUMERIC	999.99	Y LOCATION OF SEPTIC TANK
FIELD_LEN	NUMERIC	999	LENGTH OF DRAINAGE FIELD (FEET)
FIELD_WIDTH	NUMERIC	999	WIDTH OF DRAINAGE FIELD (FEET)
APPL_DRAIN	LOGICAL	YES / NO	DO ANY LAUNDRY / APPLICANCES DRAIN TO THE TANK ?
BLDG_ID	TEXT	15	UNIQUE FACILITY ID FOR EACH HOUSE / BUILDING. LINK TO OSDS_BLDG TABLE
ACCEPT_DATE	DATE	MM/DD/YYYY	DATE ACCEPTANCE INSPECTION WAS COMPLETED
XY_LOC_CODE	KEY		XY_LOC_CODE TABLE
TANK_TYPE_CODE	KEY		TANK_TYPE_CODE TABLE
SOIL_TYPE_CODE	KEY		SOIL_TYPE_CODE TABLE
MATL_CODE	KEY		MATL_CODE TABLE
FIELD_TYPE_CODE	KEY		FIELD_TYPE_CODE TABLE

REVIEW COMMENTS

TABLE NAME: OSDS_MAINT_INSP

This table would record all the inspection records for each septic tank (permit number) for each home or building. There will be many OSDS_MAINT_INSP records for each OSDS_SEPTIC record linked through the unique key – PERMIT_ID

FIELD NAME	DATA TYPE	SIZE	DESCRIPTION
PERMIT_ID	TEXT	15	UNIQUE FEATURE ID – PRIMARY KEY / USER DEFINED – LINK TO THE OSDS_SEPTIC TABLE, DUPLICATES ALLOWED
PUMPOUT_DATE	DATE	MM/DD/YYYY	DATE OF PUMPOUT – LEAVE BLANK IF ONLY INSPECTION
GAL_SEWAGE	NUMERIC	99999	GALLONS REMOVED FROM TANK DURING THIS PUMPOUT DATE (GALLONS)
INSPEC_DATE	DATE	MM/DD/YYYY	DATE OF INSPECTION – LEAVE BLANK IF A PUMPOUT
HAULER_ID_CODE	KEY		HAULER_ID_CODE TABLE
COND_CODE	KEY		COND_CODE TABLE
INSPECTOR_CODE	KEY		INSPECTOR NAME, LINK TO INSP_CODE TABLE
INSP_TYPE_CODE	KEY		REASON FOR INSPECTION – INSP_CODE TABLE

REVIEW COMMENTS

SECTION 2.
ONSITE SEWAGE DISPOSAL SYSTEM
LOOK UP TABLES

There are 7 on-site sewage disposal system look up tables defined in this database. These look up tables support the main feature tables by storing commonly used data. A definition table is defined for each look up code table for the following:

CVT_CODE
TANK_TYPE_CODE
MATL_CODE
SOIL_TYPE_CODE
FIELD_TYPE_CODE
HAULER_ID_CODE
COND_CODE
BLDG_TYPE_CODE
XY_LOC_CODE
INSPECTOR_CODE
INSP_TYPE_CODE

These tables, which the community, can use to develop their storm water drainage data base, include the following information:

Field Name - Data base field name
Data Type - Type of data (Unique Key, Text / character, numeric)
Data Size - the size of the data field
Description - a brief description

The primary key field of each table is identified using a **BOLD** font. The look up code key is the indexed key to the table.

Look up tables can be added to the data base structure as needed.

TABLE NAME: CVT_CODE

This table contains the information about each community, village or township (CVT) which may have a house / building with an OSDS. A one to one relationship.

FIELD NAME	DATA TYPE	SIZE	DESCRIPTION
CVT_CODE	KEY		UNIQUE CODE KEY – PRIMARY KEY
CVT_NAME	TEXT	25	CVT NAME (IE: WAYNE, INKSTER, FLAT ROCK, ETC.)
CVT_ADDR_1	TEXT	50	CVT MAILING ADDRESS FIELD ONE
CVT_ADDR_2	TEXT	50	CVT MAILING ADDRESS FIELD TWO
CVT_ZIP	NUMERIC	99999	CVT ZIP CODE
CONTACT_NAME	TEXT	30	NAME OF CONTACT PERSON AT CVT
PHONE	NUMERIC	999.999.9999	PHONE NUMBER
FIELD_1	TEXT	25	EXTRA TEXT FIELD

REVIEW COMMENTS

TABLE NAME: TANK_TYPE_CODE

This table contains the septic tank types. A one to one relationship.

FIELD NAME	DATA TYPE	SIZE	DESCRIPTION
TANK_TYPE_CODE	KEY		UNIQUE CODE KEY – PRIMARY KEY
TANK_TYPE_NAME	TEXT	30	SEPTIC TANK TYPE (IE: CONCRETE BOX, PLASTIC, ETC.)
FIELD_1	TEXT	25	EXTRA TEXT FIELD

REVIEW COMMENTS

TABLE NAME: MATL_CODE

This table contains the material names for the septic tank and drain field. A one to one relationship.

FIELD NAME	DATA TYPE	SIZE	DESCRIPTION
MATL_CODE	KEY		UNIQUE CODE KEY- PRIMARY KEY
MATL_NAME	TEXT	25	MATERIAL NAME (IE: CONCRETE, CINDER BLOCK, CAST IRON, RCP, VCP, UNKNOWN, DUCTILE IRON, EARTH, ETC.)

REVIEW COMMENTS

TABLE NAME: SOIL_TYPE_CODE

This table contains the different soil types. A one to one relationship.

FIELD NAME	DATA TYPE	SIZE	DESCRIPTION
SOIL_TYPE_CODE	KEY		UNIQUE CODE KEY – PRIMARY KEY
SOIL_TYPE_NAME	TEXT	30	SOIL TYPE NAME (IE: SANDY, CLAY, LOAM, SANDY-CLAY, ETC.)
SOIL_CLASS	TEXT	25	STANDARD SOIL CLASS DESCRIPTION
SOIL_TYPE_PERC	NUMERIC	9999.99	STANDARD SOIL TYPE PERCOLATION RATE (IN/HR)

REVIEW COMMENTS

TABLE NAME: FIELD_TYPE_CODE

This table contains the type of drain field associated with the septic tank. A one to one relationship.

FIELD NAME	DATA TYPE	SIZE	DESCRIPTION
FIELD_TYPE_CODE	KEY		UNIQUE CODE KEY - PRIMARY KEY
FIELD_TYPE_NAME	TEXT	25	FIELD TYPE (IE: GRAVITY, PUMP, PUMP W/ PRESSURE, OTHER, ETC.)
FIELD_1	TEXT	25	EXTRA TEXT FIELD

REVIEW COMMENTS

TABLE NAME: COND_CODE

This table contains the condition codes used in inspecting the septic tanks. A one to one relationship

FIELD NAME	DATA TYPE	SIZE	DESCRIPTION
COND_CODE	KEY		UNIQUE CODE KEY - PRIMARY KEY
COND_NAME	TEXT	25	CONDITION TYPE (IE: CRACKED, RUPTURED, OBSTRUCTION, BROKEN PIPE; ETC.)
FIELD_1	TEXT	25	EXTRA TEXT FIELD

REVIEW COMMENTS

None.

TABLE NAME: HAULER_ID_CODE

This table describes the waste hauler companies that clean out the septic tanks. There could a one to many relationship with the OSDS_SEPTIC

FIELD NAME	DATA TYPE	SIZE	DESCRIPTION
HAULER_ID_CODE	KEY		UNIQUE CODE KEY - PRIMARY KEY
HAULER_NAME	TEXT	25	NAME OF WASTER HAULER
ADDRESS1	TEXT	15	ADDRESS LINE ONE
ADDRESS2	TEXT	15	ADDRESS LINE TWO
CVT_CODE	KEY		CVT_CODE TABLE
STATE	TEXT	3	STATE TWO LETTER ABBREVIATION
ZIP	NUMERIC	99999	ZIP CODE
CONTACT_NAME	TEXT	25	CONTACT NAME FOR WASTE HAULER
PHONE	NUMERIC	999.999.9999	PHONE NUMBER
HAULER_PERMIT_NO	TEXT	15	WASTE HAULER STATE PERMIT NUMBER
DISPOSAL_SITE	TEXT	15	DISPOSAL SITE FOR WASTE HAULER DISCHARGE
PERMIT_ID	TEXT	15	UNIQUE PERMIT ID FOR THE SEPTIC TANK. OSDS_SEPTIC TABLE

REVIEW COMMENTS

TABLE NAME: XY_LOC_CODE

This table describes the method that the X-Y location of the septic tank was determined

FIELD NAME	DATA TYPE	SIZE	DESCRIPTION
XY_LOC_CODE	KEY		UNIQUE CODE KEY - PRIMARY KEY
XY_METHOD	TEXT	25	METHOD OF DETERMINING THE XY LOCATION (IE: GPS, EYEBALL, ETC.)

REVIEW COMMENTS

TABLE NAME: INSPECTOR_CODE

This table describes the inspector that inspect the septic tanks. There could a one to many relationship with the OSDS_SEPTIC

FIELD NAME	DATA TYPE	SIZE	DESCRIPTION
INSPECTOR_CODE	KEY		UNIQUE CODE KEY - PRIMARY KEY
INSP_NAME	TEXT	25	NAME OF INSPECTOR
ADDRESS1	TEXT	15	ADDRESS LINE ONE
ADDRESS2	TEXT	15	ADDRESS LINE TWO
CVT_CODE	KEY		CVT_CODE TABLE
STATE	TEXT	3	STATE TWO LETTER ABBREVIATION
ZIP	NUMERIC	99999	ZIP CODE
PHONE	NUMERIC	999.999.9999	PHONE NUMBER

REVIEW COMMENTS

TABLE NAME: BLDG_TYPE_CODE

This table describes the building types associated with a septic tank.

FIELD NAME	DATA TYPE	SIZE	DESCRIPTION
BLDG_TYPE_CODE	KEY		UNIQUE CODE KEY - PRIMARY KEY
B:LDG_TYPE	TEXT	25	BUILDING TYPE (IE: SINGLE RESIDENTIAL, STRIP COMMERCIAL, LARGE COMMERCIAL, INDUSTRIAL, MULTIFAMILY, ETC.)
PERMIT_ID	TEXT	15	UNIQUE PERMIT ID FOR THE SEPTIC TANK. OSDS_SEPTIC TABLE

REVIEW COMMENTS

TABLE NAME: INSP_TYPE_CODE

This table describes the building types associated with a septic tank.

FIELD NAME	DATA TYPE	SIZE	DESCRIPTION
INSP_TYPE_CODE	KEY		UNIQUE CODE KEY - PRIMARY KEY
INSP_TYPE	TEXT	25	INSPECTION TYPE (IE: ACCEPTANCE, PROPERTY TRANSFER, COMPLAINT, 5 YR STANDARD, OTHER, ETC.)
PERMIT_ID	TEXT	15	UNIQUE PERMIT ID FOR THE SEPTIC TANK. OSDS_SEPTIC TABLE

REVIEW COMMENTS

The following figure shows the relationships of the attribute data tables and the look up or code tables.

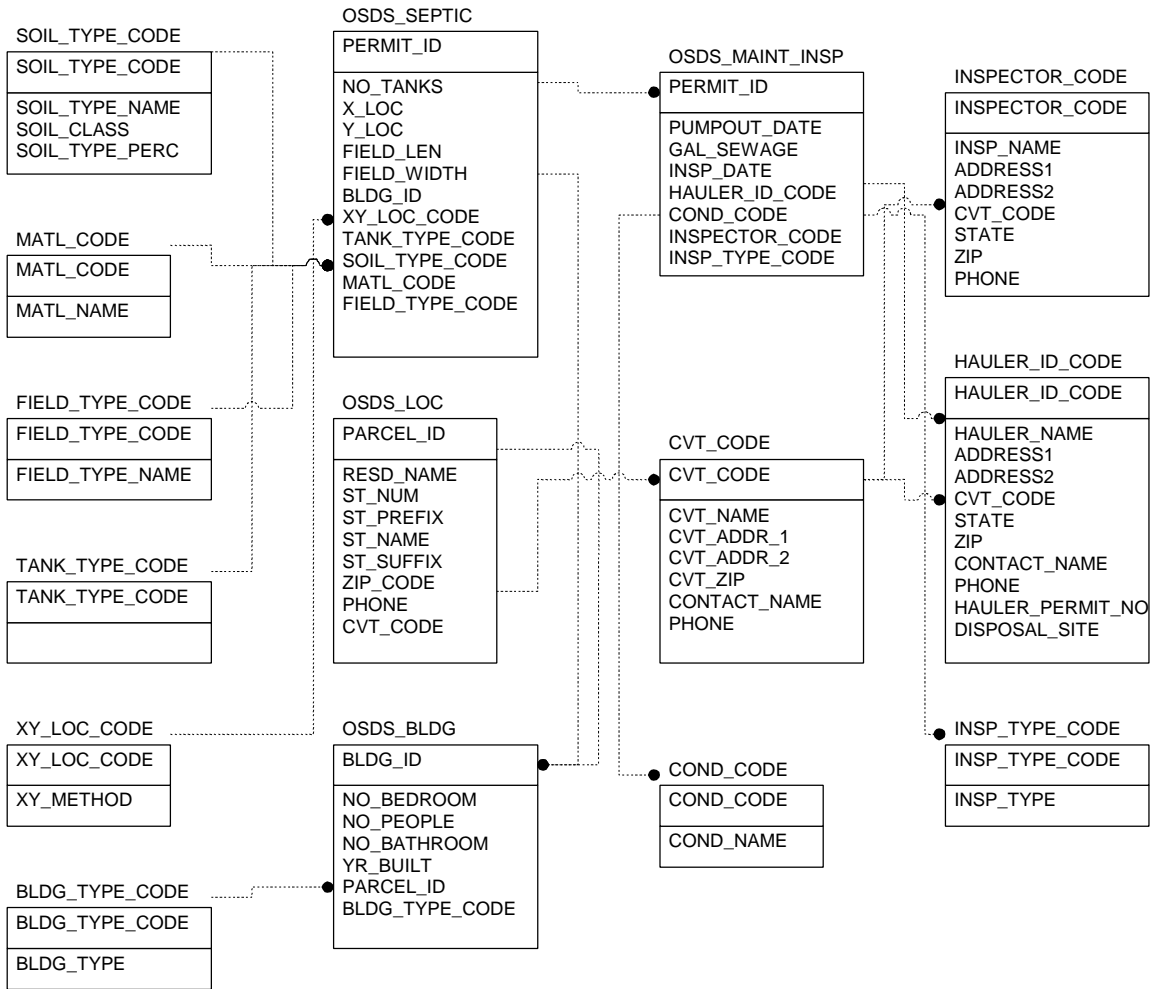

OSDS		Edit Date: 4/23/99 4:22:51 PM
Onsite Sewage Disposal Wayne County Rouge Program		
Microsoft Access	Rev: 0	Creator: Bristol
Filename:		

**SECTION 3.
ONSITE DEWAGE DISPOSAL SYSTEM
ARC/INFO TABLES**

There are three ARC/Info tables defined in this document. These are the required tables used by ARC/Info.

- Node Attribute Table (NAT)
- Arc Attribute Table (AAT)
- Polygon Attribute Table (PAT)

Once the proper arc, node or polygon table has been created in ARC/Info, the link can be made via the **XXX_ID** field found in the Arc/Info table and in each of the attribute tables. These tables as presented in Section 1 are called RELATE tables in Arc/Info.

TABLE NAME: NODE ATTRIBUTE TABLE (BUILDING_NAT)

This table would be used to describe the BLDG tables.

FIELD NAME	DATA TYPE	WIDTH / DISPLAY	DESCRIPTION
ARC#	NUMERIC	4 / 5	UNIQUE PRIMARY KEY – ASSIGNED BY ARC/INFO
BUILDING#	NUMERIC	4 / 5	INTERNAL FEATURE ID ASSIGNED BY ARC/INFO
BUILDING_ID	NUMERIC	4 / 5	USER DEFINED FEATURE ID
BLDG_ID	TEXT	15	UNIQUE BUILDING ID FROM OSDS_BLDG
CONV_SOURCE	KEY	1 / 1	SOURCE OF DATA USED IN THE CONVERSION PROCESS (IE: QUARTER SECTION MAPS, DESIGN DRAWINGS, GPS, OTHER, INKNOWN, ETC.)
REV_DATE	DATE	MM/DD?YYYY	DATE THE COVERAGE WAS CHANGED
STATUS_CODE	KEY		STATUS OF FEATURE (IE: OPERATIONAL, OUT OR SERVICE, ABANDONDED, ETC.)
FAC_SYM	NUMERIC	3 / 3	PLOTTING SYMBOL FOR THE STD MAP DISPLAY

WIDTH / DISPLAY - The field width in the database and the display width in all output.

TABLE NAME: NODE ATTRIBUTE TABLE (SEPTIC_NAT)

This table would be used to describe the SEPTIC tables.

FIELD NAME	DATA TYPE	WIDTH / DISPLAY	DESCRIPTION
ARC#	NUMERIC	4 / 5	UNIQUE PRIMARY KEY – ASSIGNED BY ARC/INFO
BUILDING#	NUMERIC	4 / 5	INTERNAL FEATURE ID ASSIGNED BY ARC/INFO
BUILDING_ID	NUMERIC	4 / 5	USER DEFINED FEATURE ID
PERMIT_ID	TEXT	15	UNIQUE PERMIT ID FROM OSDS_SEPTIC
CONV_SOURCE	KEY	1 / 1	SOURCE OF DATA USED IN THE CONVERSION PROCESS (IE: QUARTER SECTION MAPS, DESIGN DRAWINGS, GPS, OTHER, INKNOWN, ETC.)
REV_DATE	DATE	MM/DD?YYYY	DATE THE COVERAGE WAS CHANGED
STATUS_CODE	KEY		STATUS OF FEATURE (IE: OPERATIONAL, OUT OR SERVICE, ABANDONDED, ETC.)
FAC_SYM	NUMERIC	3 / 3	PLOTTING SYMBOL FOR THE STD MAP DISPLAY

WIDTH / DISPLAY - The field width in the database and the display width in all output.

TABLE NAME: ARC ATTRIBUTE TABLE (AAT)

This table would probably not be used. There are neither lines nor arcs in this data base definition.

FIELD NAME	DATA TYPE	WIDTH / DISPLAY	DESCRIPTION
FNDE#	NUMERIC	4 / 5	FROM NODE ASSIGNED BY ARC/INFO
TNDE#	NUMERIC	4 / 5	TO NODE ASSIGNED BY ARC/INFO
LPOLY#	NUMERIC	4 / 5	LEFT POLYGON ASSIGNED BY ARC/INFO
RPOLY#	NUMERIC	4 / 5	RIGHT POLYGON ASSIGNED BY ARC/INFO
LENGTH#	NUMERIC	8.5 / 18.5	LENGTH OF ARC ASSIGNED BY ARC/INFO
SEPTIC#		4 / 5	INTERNAL FEATURE ID ASSIGNED BY ARC/INFO
SEPTIC_ID	NUMERIC	4 / 5	USER DEFINED FEATURE ID

WIDTH / DISPLAY - The field width in the database and the display width in all output.

TABLE NAME: POLYGON ATTRIBUTE TABLE (FIELD_PAT)

This table would be used if the drain field that has a length and a width were to be mapped.

FIELD NAME	DATA TYPE	WIDTH / DISPLAY	DESCRIPTION
AREA#	NUMERIC	8.5 / 18.5	AREA – ASSIGNED BY ARC/INFO
PERIMETER#	NUMERIC	8.4 / 18.5	PERMETER ASSIGNED BY ARC/INFO
SEPTIC#	NUMERIC	4 / 5	UNIQUE FEATURE ID – ASSIGNED BY ARC/INFO
SEPTIC_ID	NUMERIC	4 / 5	USER DEFINED FEATURE ID
PERMIT_ID	TEXT	15	UNIQUE FACILITY ID FOUND IN THE ATTRIBUTE TABLES
CONV_SOURCE	KEY	1 / 1	SOURCE OF DATA USED IN THE CONVERSION PROCESS (IE: QUARTER SECTION MAPS, DESIGN DRAWINGS, GPS, OTHER, INKNOWN, ETC.)
REV_DATE	DATE	MM/DD/YYYY	DATE THE COVERAGE WAS CHANGED
STATUS_CODE	KEY		STATUS OF FEATURE (IE: OPERATIONAL, OUT OR SERVICE, ABANDONDED, ETC.)
FAC_SYM	NUMERIC	3 / 3	PLOTTING SYMBOL FOR STD MAP DISPLAY

WIDTH / DISPLAY - The field width in the database and the display width in all output.

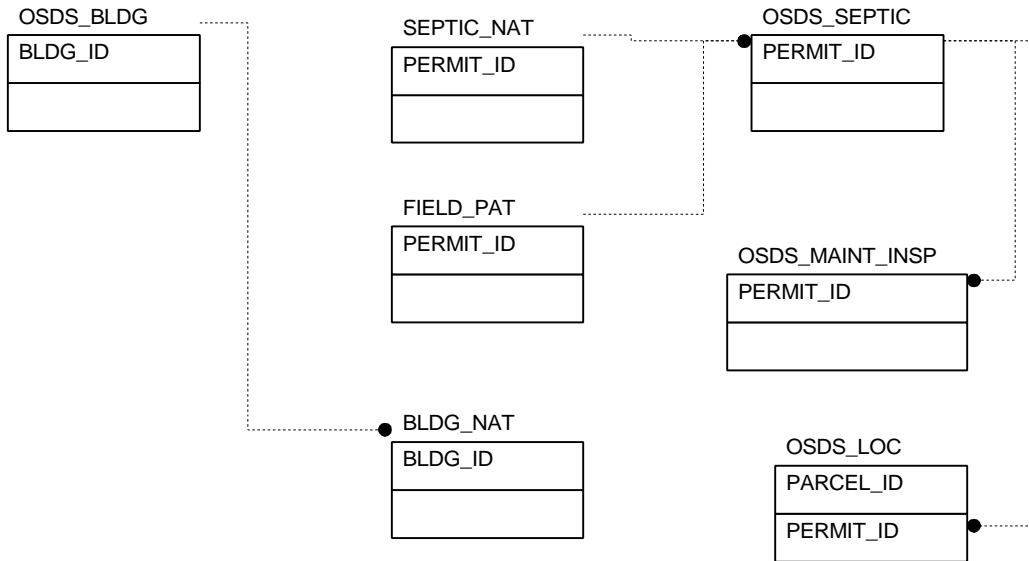

OSDS ARC/INFO		Edit Date: 4/23/99 4:29:40 PM
Onsite Sewage Disposal System Wayne County Rouge Program Office		
Microsoft Access	Rev: 0	Creator: Bristol
Filename: OSDSArcInfo.vsd		

**SECTION 4.
STORM WATER DRAINAGE
ARCVIEW TABLES**

For those communities that will be building their storm water drainage data base and conducting mapping using ArcView, there are several tables required by ArcView that need to be created. These tables include the following:

- Point Theme
- Arc Theme
- Area Theme

These tables are required to be in a Xbase format (dbf). The two primary fields, which are used by ArcView, are the SHAPE and ID fields. The link or join to the storm water drainage attribute tables is via the ID field. ArcView scripts can be written to enable the ID field to be populated during graphic data development.

TABLE NAME: POINT THEME (BLDG_SHP FILE)

For use in mapping the building or septic tank points.

FIELD NAME	DATA TYPE	WIDTH	DESCRIPTION
SHAPE	TEXT	POINT	UNIQUE PRIMARY KEY - ASSIGNED BY ARCVIEW. ALWAYS "POINT"
ID	NUMERIC	4 / 5	INTERNAL FEATURE ID ASSIGNED BY ARCVIEW
BLDG_ID	TEXT	15	UNIQUE BUILDING ID FROM ATTRIBUTE TABLES (OSDS_BLDG)
CONV_SOURCE	KEY	1 / 1	SOURCE OF DATA USED IN THE CONVERSION PROCESS (IE: QUARTER SECTION MAPS, DESIGN DRAWINGS, GPS, OTHER, INKNOWN, ETC.)
REV_DATE	DATE	MM/DD?YYYY	DATE THE THEME WAS CHANGED
STATUS_CODE	KEY		STATUS OF FEATURE (IE: OPERATIONAL, OUT OR SERVICE, ABANDONDED, ETC.)
FAC_SYM	NUMERIC	3 / 3	PLOTTING SYMBOL FOR THE STD MAP DISPLAY

TABLE NAME: POINT THEME (SEPTIC_SHP FILE)

For use in mapping the building or septic tank points.

FIELD NAME	DATA TYPE	WIDTH	DESCRIPTION
SHAPE	TEXT	POINT	UNIQUE PRIMARY KEY - ASSIGNED BY ARCVIEW. ALWAYS "POINT"
ID	NUMERIC	4 / 5	INTERNAL FEATURE ID ASSIGNED BY ARCVIEW
PERMIT_ID	TEXT	15	UNIQUE PERMIT ID FROM ATTRIBUTE TABLES (OSDS_SEPTIC)
CONV_SOURCE	KEY	1 / 1	SOURCE OF DATA USED IN THE CONVERSION PROCESS (IE: QUARTER SECTION MAPS, DESIGN DRAWINGS, GPS, OTHER, INKNOWN, ETC.)
REV_DATE	DATE	MM/DD?YYYY	DATE THE THEME WAS CHANGED
STATUS_CODE	KEY		STATUS OF FEATURE (IE: OPERATIONAL, OUT OR SERVICE, ABANDONDED, ETC.)
FAC_SYM	NUMERIC	3 / 3	PLOTTING SYMBOL FOR THE STD MAP DISPLAY

TABLE NAME: LINE THEME (SHP FILE)

This table would probably not be used.

FIELD NAME	DATA TYPE	WIDTH	DESCRIPTION
SHAPE	TEXT	LINE	UNIQUE PRIMARY KEY - ASSIGNED BY ARCVIEW. ALWAYS "LINE"
ID	NUMERIC	4 / 5	INTERNAL FEATURE ID ASSIGNED BY ARCVIEW

TABLE NAME: POLYGON THEME (FIELD_SHP FILE)

This table would be used if the drain field area were to be mapped.

FIELD NAME	DATA TYPE	WIDTH	DESCRIPTION
SHAPE	TEXT	POLYGON	UNIQUE PRIMARY KEY – ASSIGNED BY ARCVIEW. ALWAYS “POLYGON”
ID	NUMERIC	4 / 5	INTERNAL FEATURE ID ASSIGNED BY ARCVIEW
PERMIT_ID	TEXT	15	UNIQUE PERMIT ID FROM ATTRIBUTE TABLES (OSDS_SEPTIC)
CONV_SOURCE	KEY	1 / 1	SOURCE OF DATA USED IN THE CONVERSION PROCESS (IE: QUARTER SECTION MAPS, DESIGN DRAWINGS, GPS, OTHER, INKNOWN, ETC.)
REV_DATE	DATE	MM/DD?YYYY	DATE THE THEME WAS CHANGED
STATUS_CODE	KEY		STATUS OF FEATURE (IE: OPERATIONAL, OUT OR SERVICE, ABANDONDED, ETC.)
FAC_SYM	NUMERIC	3 / 3	PLOTTING SYMBOL FOR THE STD MAP DISPLAY

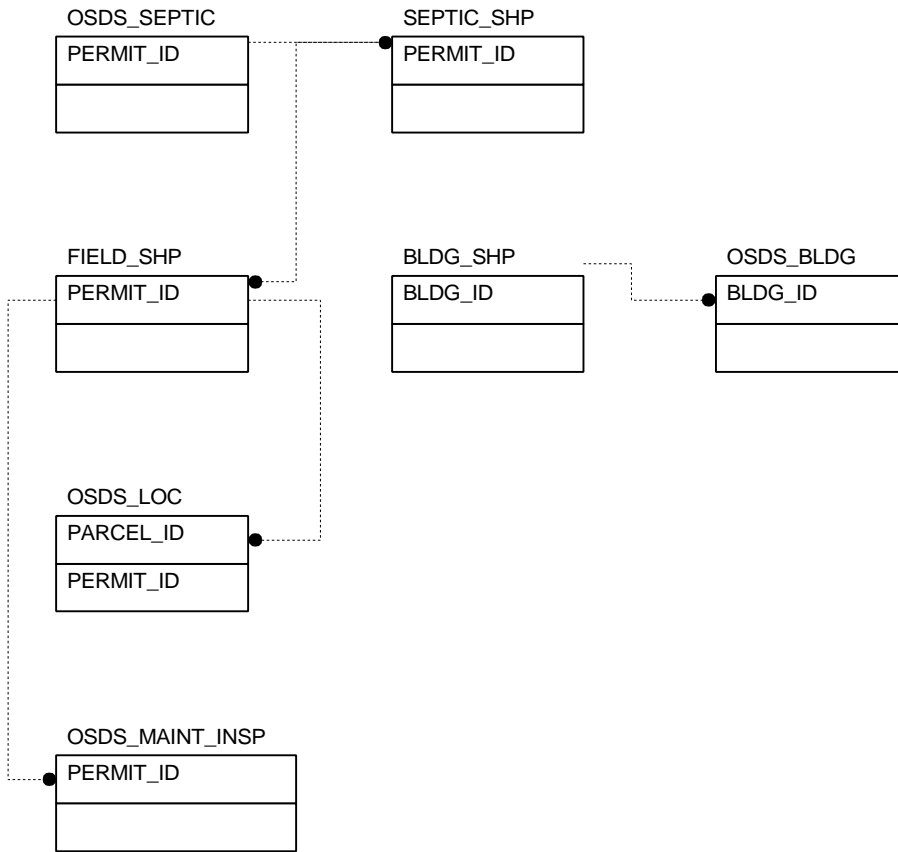

OSDS ARCVIEW		Edit Date: 4/23/99 4:32:50 PM
Onsite Sewage Disposal System Wayne County Rouge Program Office		
Microsoft Access	Rev: 0	Creator: Bristol
Filename: OSDSArcView.vsd		